

TPV



WO1. Mike "Penv" Penver

Crew

PILOT
Pit: 6
Gnr: 7

CO-PILOT
Pit: 5
Gnr: 7

GUNNER A
Gnr: 8

GUNNER B
Gnr: 4

Pilot/Co-Pilot

1 Minigun (FQL, F, FQR) To Hit: 2D10+D8 (+1) Damage: Mid(+1)

○○○○○○○○

Gunner A

1 M60 (FQL, RQL)
To Hit: 2D6+D8 Damage: Low

Gunner B

1 M60 (FQR, RQR)
To Hit: 2D6+D4 Damage: Low

Pilot/Co-Pilot
XM157 Rocket Pod

(F) - Max 10 Random Area Hit

Pilot/Co-Pilot
XM157 Rocket Pod

(F) - Max 10 Random Area Hit

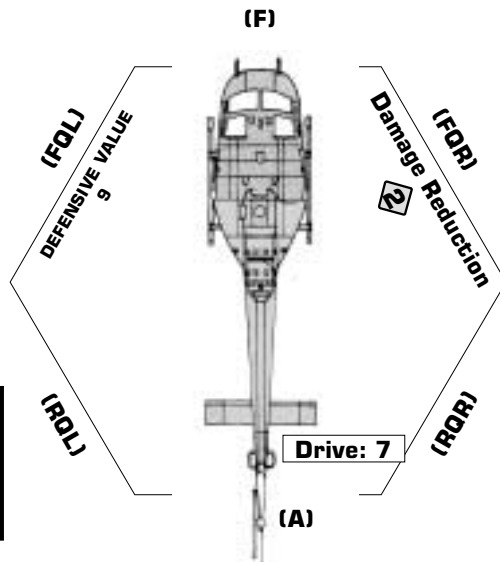

Turn Cost: 3
Tight Turn Cost: D6 +3

DAMAGE TRACK

→	2		w	*	7			*
	w	6		w		5		w
	1	4	*		w	3	*	2
								X

- CRITICAL HITS**
- Pilot Killed.
 - Gunner A's M60's Jams - No more firing at all.
 - Rocket Pod Malfunction - fire 1D4 Rockets to range 2D6 to hit!
 - Engine Stutters - Reduce speed by 3 for next turn only.
 - Controls Hit - increase turn cost by 1.
 - Pilot breaks wind - no effect.
 - Rocket Pod Malfunction - lose 1D4 Rockets.
 - Gunner B Killed - No firing his M60.
 - Minigun jams - no more firing.
 - Fuel Tank Hit - 1D4+3 more turns until a controlled landing
 - Main rotor blown off - Huey crashes in a random hex (bowl 1D6)

- WEAPONS**
- Rockets** - Short (Minimum Range) 3 (+1), Med 4-6, Long 7-12 (-1)
 - M60** - Short 1-2 (+1), Med 3-6, Long 7-9 (-1)
 - Minigun** - Short 1-3 (+1), Med 4-6, Long 7-12 (-1)
 - Mini Gun may NOT expend double ammunition.

TPV



Capt. Frankie "Garden" Shedden

Crew

PILOT
Pit: 8
Gnr: 7

CO-PILOT
Pit: 5
Gnr: 7

GUNNER A
Gnr: 8

GUNNER B
Gnr: 4

Pilot/Co-Pilot
1 Minigun (FQL, F, FQR) To Hit: 2D10+D8 (+1) Damage: Mid(+1)
○○○○○○○○

Gunner A
1 M60 (FQL, RQL)
To Hit: 2D6+D8 Damage: Low

Pilot/Co-Pilot
XM157 Rocket Pod
(F) - Max 10 Random Area Hit

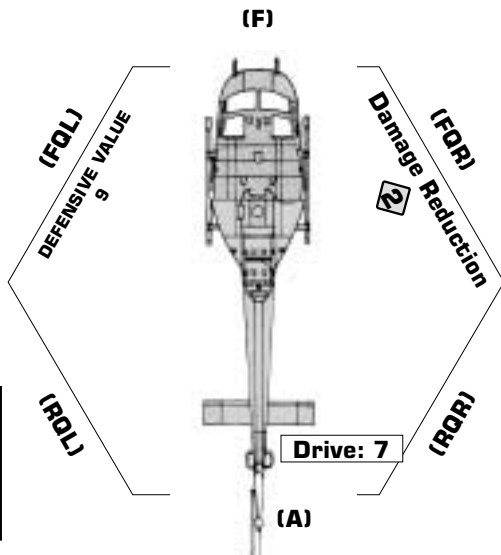

Gunner B
1 M60 (FQR, RQR)
To Hit: 2D6+D4 Damage: Low

Pilot/Co-Pilot
XM157 Rocket Pod
(F) - Max 10 Random Area Hit

Turn Cost: 3
Tight Turn Cost: D4 +3

DAMAGE TRACK

→	2		w	*	7			*
	w	6		w		5		w
	1	4	*		w	3	*	2
								X

- CRITICAL HITS**
- Pilot Killed.
 - Gunner A's M60's Jams - No more firing at all.
 - Rocket Pod Malfunction - fire 1D4 Rockets to range 2D6 to hit!
 - Engine Stutters - Reduce speed by 3 for next turn only.
 - Controls Hit - increase turn cost by 1.
 - Pilot breaks wind - no effect.
 - Rocket Pod Malfunction - lose 1D4 Rockets.
 - Gunner B Killed - No firing his M60.
 - Minigun jams - no more firing.
 - Fuel Tank Hit - 1D4+3 more turns until a controlled landing
 - Main rotor blown off - Huey crashes in a random hex (bowl 1D6)

- WEAPONS**
- Rockets** - Short (Minimum Range) 3 (+1), Med 4-6, Long 7-12 (-1)
 - M60** - Short 1-2 (+1), Med 3-6, Long 7-9 (-1)
 - Minigun** - Short 1-3 (+1), Med 4-6, Long 7-12 (-1)
 - Mini Gun may NOT expend double ammunition.

TPV



WO1. Ben "The Doc" Roberts

Crew

PILOT
Pit: 6
Gnr: 7

CO-PILOT
Pit: 5
Gnr: 7

GUNNER A
Gnr: 8

GUNNER B
Gnr: 4

Pilot/Co-Pilot

1 Minigun (FQL, F, FQR) To Hit: $2D10 + D8 (+1)$ Damage: Mid(+1)

○○○○○○○○

Pilot/Co-Pilot
XM157 Rocket Pod

(F) - Max 10 Random Area Hit

○○○○○○

Pilot/Co-Pilot
XM157 Rocket Pod

(F) - Max 10 Random Area Hit

○○○○○○

Gunner A

1 M60 (FQL, RQL)
To Hit: $2D6 + D8$ Damage: Low

Gunner B

1 M60 (FQR, RQR)
To Hit: $2D6 + D4$ Damage: Low

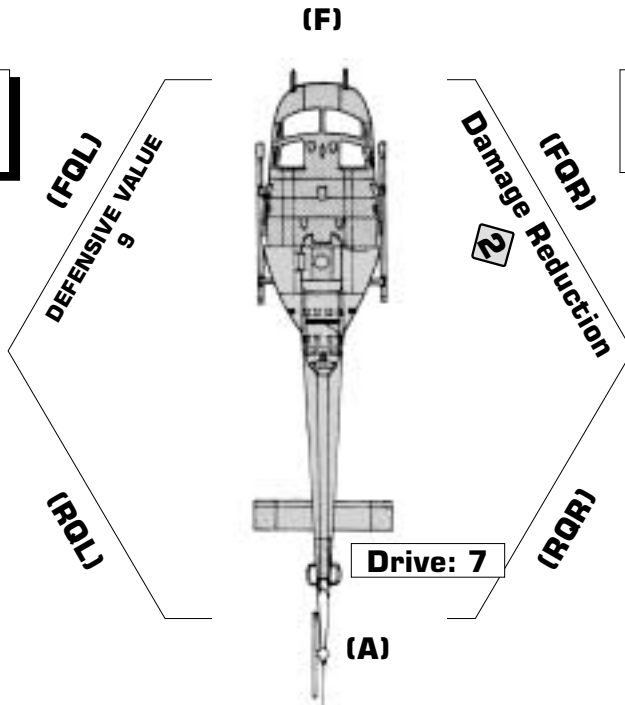

Turn Cost: 3

Tight Turn Cost: D6 +3

DAMAGE TRACK

→	2		w	*	7			*
	w	6		w		5		w
	1	4	*		w	3	*	2
								X

- CRITICAL HITS**
- Pilot Killed.
 - Gunner A's M60's Jams - No more firing at all.
 - Rocket Pod Malfunction - fire 1D4 Rockets to range 2D6 to hit!
 - Engine Stutters - Reduce speed by 3 for next turn only.
 - Controls Hit - increase turn cost by 1.
 - Pilot breaks wind - no effect.
 - Rocket Pod Malfunction - lose 1D4 Rockets.
 - Gunner B Killed - No firing his M60.
 - Minigun jams - no more firing.
 - Fuel Tank Hit - 1D4+3 more turns until a controlled landing
 - Main rotor blown off - Huey crashes in a random hex (bowl 1D6)

- WEAPONS**
- Rockets** - Short (Minimum Range) 3 (+1), Med 4-6, Long 7-12 (-1)
 - M60** - Short 1-2 (+1), Med 3-6, Long 7-9 (-1)
 - Minigun** - Short 1-3 (+1), Med 4-6, Long 7-12 (-1)
 - Mini Gun may NOT expend double ammunition.